



VENTED CYLINDER RANGE

FULL RANGE OF VENTED
CYLINDERS MANUFACTURED
FROM EITHER COPPER OR
STAINLESS STEEL



ONE NAME. EVERY SOLUTION.

WWW.GLEDHILL.NET



BUILT ON EXPERIENCE

THE GLEDHILL BRAND HAS BEEN SYNONYMOUS WITH QUALITY MANUFACTURING AND EXPERTISE FOR ALMOST A CENTURY.

Our vented cylinders are produced across two manufacturing centres: Centre of Excellence for copper in Birmingham and Centre of Excellence for stainless steel at our Blackpool headquarters. This enables us to produce a uniformed and consistent quality across our products. Each centre has a dedicated team of skilled experts, producing standard and bespoke cylinders.



CONTENTS

- 02. BUILT ON EXPERIENCE
- 04. GLEDHILL VENTED CYLINDER RANGE
- 05. OUR NETWORK
- 06. SECURE ORDER TO FAST DELIVERY
- 07. THE COMPLETE BESPOKE CYLINDER SERVICE
- 08. STORAGE CAPACITY
- 09. OTHER CONSIDERATIONS

CYLINDERS:

- 10. ENVIROFOAM STAINLESS
- 11. ENVIROFOAM COPPER (INDIRECT)
- 12. HIGH RECOVERY COILS
- 13. SUPER RECOVERY CYLINDERS
- 14. ENVIROFOAM COPPER (DIRECT)
- 15. COMBINATION UNITS
- 16. SUNSPEED
- 17. TWIN COIL CYLINDERS
- 18. COMMERCIAL CYLINDERS
- 19. RECTANGULAR TANKS
- 20. TORRENT STAINLESS
- 22. SPECIAL ORDERS

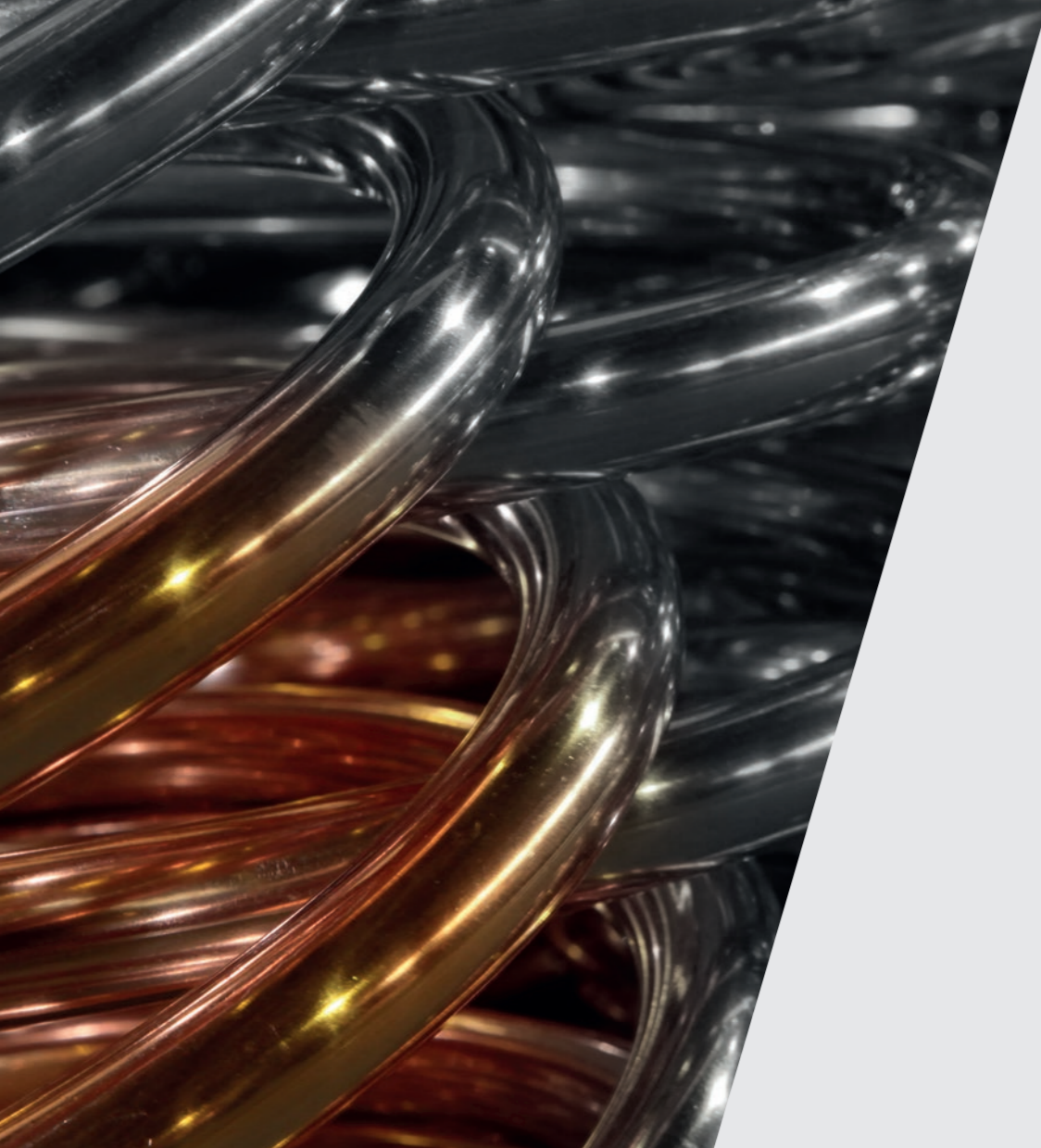

GLEDHILL VENTED CYLINDER RANGE

GLEDHILL PROVIDES STANDARD AND BESPOKE CYLINDERS TO SUIT YOUR NEEDS. THE STANDARD RANGE IS MANUFACTURED FROM BOTH STAINLESS STEEL AND COPPER.

Our copper range includes cylinders and combination units for all traditional domestic applications; commercial and industrial cylinders and calorifiers; products for use with off peak electricity and thermal stores suitable for use with a wide range of alternative energy.

OUR NETWORK

IN ANSWER TO THE DEMANDS OF CUSTOMERS WE HAVE SPECIFICALLY TAILORED OUR DISTRIBUTION NETWORK TO ENSURE OUR PRODUCTS REACH THEIR DESTINATION IN A DIRECT AND EFFICIENT MANNER.

Our unique structure, consisting of five distribution hubs, is geographically situated for effective, widespread product availability. Headed by our central sales and logistics team at our Blackpool headquarters and transported via our own fleet of Gledhill vehicles, we have ultimate control over the delivery of our products, enabling us to add value to our customers, meet demanding orders and high service expectations.

TRAINING

To ensure a consistently high standard of copper cylinder, Gledhill now has a dedicated training facility at the Centre of Excellence for copper in Birmingham. Here, all aspects of copper brazing and forming, as well as being given the technical theory behind copper cylinder manufacture, is instilled and championed.





THE COMPLETE BESPOKE CYLINDER SERVICE

ORDERING YOUR BESPOKE CYLINDER COULDN'T BE SIMPLER.

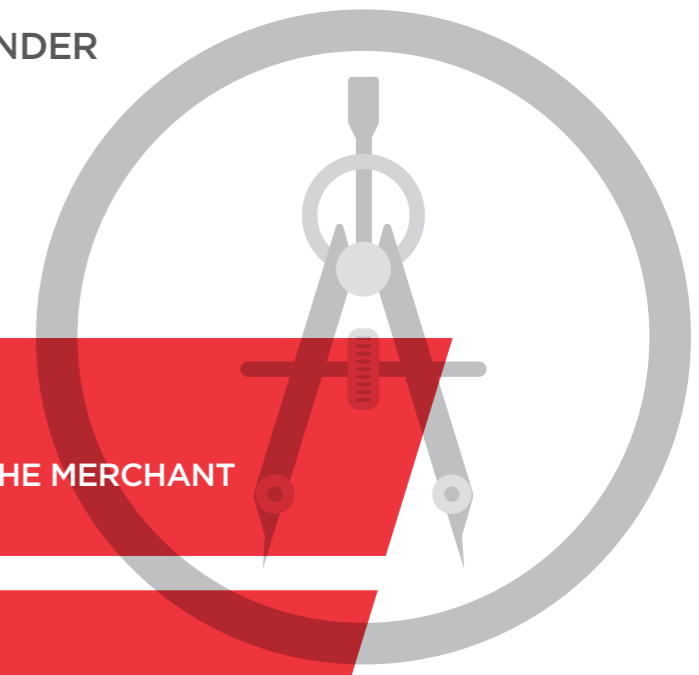

SECURE ORDER TO FAST DELIVERY

GLEDHILL IS RENOWNED FOR OUR CAPABILITY TO PRODUCE COPPER CYLINDERS TO CUSTOM SPECIFICATIONS.

The versatility of copper makes it the perfect choice of material to produce bespoke, tailor-made cylinders that can be manufactured in a fast turnaround time. This has led to high demand, particularly for bespoke orders and one-off specials, that can be custom-made.

The buoyant demand for copper specials comes from a wide range of installations; from matching the exact specification of an old domestic cylinder that needs replacing, to creating a horizontal cylinder to fit into the confined space of an attic.

Cylinder sizes can range from a 45-litre cylinder for use on pleasure boats, to a 450-litre industrial-sized model for use in commercial premises.

These cylinders are all manufactured in compliance with BS1566 and comply with 2010 Part L1B Building Regulations Replacement Cylinder requirements.



PLACE YOUR ORDER
WITH ALL YOUR REQUIREMENTS AT THE MERCHANT



CONFIRMATION
RECEIVE CONFIRMATION OF THE PRICE WITHIN ONE HOUR



MANUFACTURED
AT OUR CENTRES OF EXCELLENCE HERE IN THE UK



NEXT DAY DELIVERY
TO ANY MAINLAND UK ADDRESS
(ON SELECTED MODELS ONLY)



STORAGE CAPACITY

OUR VENTED CYLINDERS ARE AVAILABLE IN A RANGE OF CONFIGURATIONS TO SUIT THE DEMANDS OF DIFFERENT APPLICATIONS. USE THE CHART BELOW TO FIND A SUITABLE CYLINDER TO MEET YOUR REQUIREMENTS, BASED ON CAPACITY OR SIZE.

Direct cylinder capacities shown in litres (reduce by 2.5% for indirect models)							
Height		Diameter					
mm	Inches	300mm (12")	350mm (14")	375mm (15")	400mm (16")	450mm (18")	500mm (20")
600	24	35	48	55	60	77	-
675	27	40	55	62	70	86	-
750	30	45	62	70	80	98	-
825	33	50	69	78	89	109	-
900	36	55	74	87	96	120	136
975	39	60	83	95	107	135	147
1050	42	65	90	103	115	144	158
1200	48	75	103	118	134	166	190
1350	54	-	-	-	-	-	227
1500	59	-	130	148	170	218	245
1800	71	118	164	180	206	277	318

A range of sizes from the table above are also available manufactured from stainless steel, please see page 10 for further details. Other sizes are available, please email our sales and logistics team at orders@gledhill.net for further details.

Standard combination cylinder capacities			
Height (mm)	Diameter (mm)	Capacity	
		Hot (litres)	Cold (litres)
750	450	60	20
900	450	85	20
1075	450	115	20
1200	450	120	40
1400	450	145	40
1500	450	166	40
1850	450	210	40
1200	500	145	45
1500	450	166	40

OTHER CONSIDERATIONS

WHAT ELSE DO YOU NEED TO CONSIDER WHEN ORDERING A GLEDHILL CYLINDER?

GRADES OF CYLINDER

There are three 'grades' of vented cylinder G1, G2, G3. All are built to the same manufacturing standard, the principle difference between the three grades is the gauge of the copper sheet used. To determine the grade required measure the distance from the waterline in the header (or feed and expansion) tank serving the cylinder and the base of the cylinder. This measurement is known as the 'working head' and determines the grade of cylinder to be used.

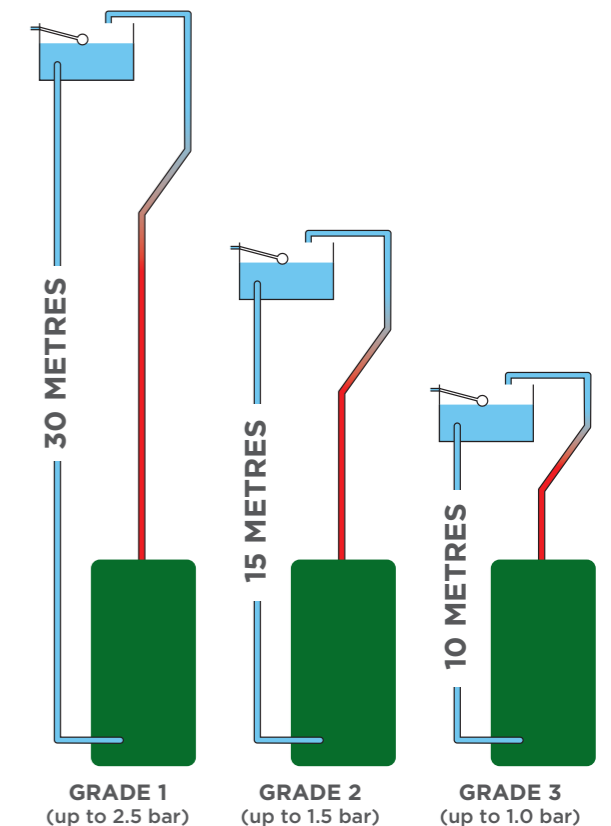

GRAVITY COIL

When ordering your Gledhill cylinder, you would need to specify if it requires a gravity coil. This is where the hot water circulation is attained by using the natural convection current rather than by the use of a circulation pump to 'force' the water around the system. The main difference in the cylinder design between a pumped and gravity circulation system is that the coils are larger in the gravity systems to provide less resistance and increase the flow rate.

Additional components available at time of order*			
Extras code	Description	Extras code	Description
EX001	Compression fittings per 4	EX019	20 ltr copper F&E tank (high temp.)
EX002	Shower take off	EX020	40 ltr copper F&E tank (high temp.)
EX003	Extra tapping added	EX021	50 ltr copper F&E tank (high temp.)
EX004	Drain cock added	EX022*	XC010 - cylinder stat
EX006	14" immersion heater	EX023*	XC007 - Brawa mixer valve
EX007	27" immersion heater	EX025*	XB482 & XB081 - Torrent ECO immersion and stat
EX008	High recovery coil	EX025*	SH003 - Torrent Stainless immersion
EX009	Gravity coil	EX035	Solid fuel tappings 28mm
EX013*	FT206 & FT429 - Part 2 ball valve & float	EX036	Side entry immersion boss x1
EX016	Stretched coil	EX037	Side entry immersion boss x2
EX017	Opposite side coil (flow & return)	EX049*	XB343 plastic F&E tank
EX018	Showercyl coil	EX050	Secondary return

*Contact Gledhill Spares to place an order for components: EX013, EX022, EX025 (Torrent ECO or Torrent Stainless available) & EX049.

ENVIROFOAM STAINLESS

STAINLESS STEEL VENTED CYLINDER, THE TRUE REPLACEMENT FOR YOUR COPPER CYLINDER.

Manufactured to comply with the HWA standard for stainless steel vented cylinders, these cylinders also have strong environmental credentials including:

- Industry leading 35mm HCFC free insulation
- Exceptionally low standing heat loss
- Insulation incorporates Polyol which is derived from rapeseed oil - a fully renewable resource
- With a duplex stainless steel internal cylinder, the product is fully recyclable at the end of its working life

With the open vented stainless steel cylinder, you will also benefit from:

- Next day lead time availability
- Easy access to immersion heater boss
- 400mm diameter models have 22mm compressions
- 450mm x 900mm model has 22mm compressions
- Remaining 450mm diameter models have 22mm compressions on coil and 28mm on cold feed and hot water draw off

KEY FEATURES

- 2017 ErP compliant
- Tapping positions to BS1566 specifications
- 10 year warranty
- Duplex stainless steel
- Shower take-off/secondary return on all models as standard
- 100% recyclable

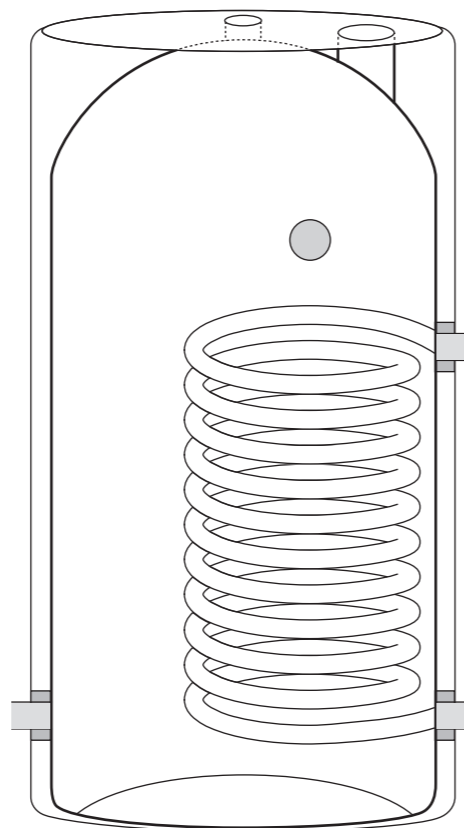

Indirect specifications						
Gledhill code	ErP rating	BS 1566 ref	Cylinder height (mm)	Cylinder diameter (mm)	Capacity (litres)	Rating (kW)
SE36X18IND	C	7	900	450	117	15
SE42X18IND	C	8	1050	450	140	20
SE48X18IND	C	9	1200	450	162	23
SE36X16IND	C	2	900	400	96	14
SE42X16IND	C	3	1050	400	114	16
Direct Specifications						
SE36X18DIR	C	7	900	450	117	N/A

ALL DIMENSIONS EXCLUDE 35MM INSULATION.

ENVIROFOAM COPPER

COPPER VENTED INDIRECT CYLINDER FOR USE WITH A CONVENTIONAL BOILER.

Manufactured to BS1566 and 2017 ErP compliant, these cylinders have strong environmental credentials including:

- Industry leading 35mm HCFC free insulation
- Exceptionally low standing heat loss
- Insulation incorporates Polyol which is derived from rapeseed oil - a fully renewable resource
- With a copper internal cylinder, the product is fully recyclable at the end of its working life

As well as being the most attractive open vented copper cylinder available on the market, you will also benefit from:

- Next day lead time availability
- Standard 1 inch male & female tapings with optional compression fittings available
- 25 minute recovery time
- Easy access to immersion heater boss

KEY FEATURES

- 2017 ErP compliant
- Standard 1 inch male & female tapings with optional compression fittings available
- 10 year warranty
- Low standing heat loss
- 100% recyclable
- Secondary return is an optional extra available on larger models

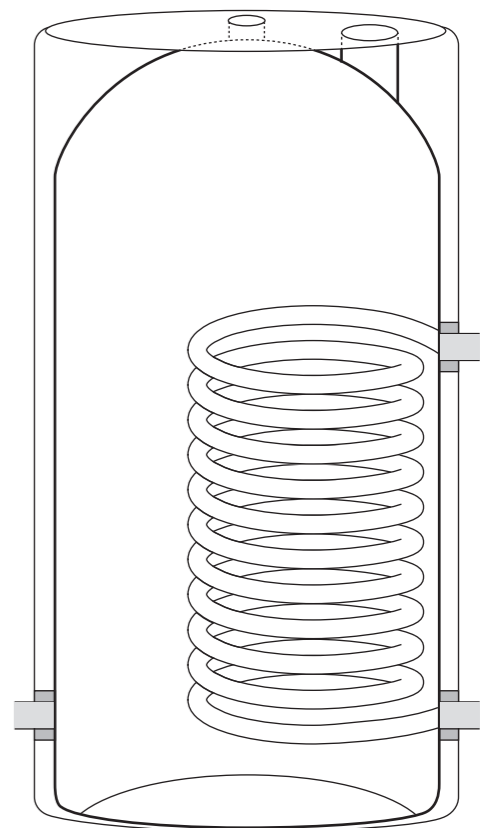

LOOKING FOR BESPOKE?
PLEASE SEE SPECIAL REQUEST FORMS

Gledhill code	ErP rating	BS 1566 ref	Cylinder height (mm)	Cylinder diameter (mm)	Capacity (litres)	Rating (kW)
BIND15	C	2	900	400	96	11
BIND16	C	3	1050	400	115	14
BIND19	B	4	675	450	86	9
BIND20	C	5	750	450	98	11
BIND21	C	6	825	450	109	13
BIND22	C	7	900	450	120	14
BIND23	C	8	1050	450	144	16
BIND24	C	9	1200	450	166	17
BIND25	C	9E	1500	450	218	22
BIND27	C	10	1200	500	202	21

ALL DIMENSIONS EXCLUDE 35MM INSULATION. EXTRA COMPONENTS ARE AVAILABLE WITH THIS PRODUCT. PLEASE SEE PAGE 9 FOR MORE DETAILS.

HIGH RECOVERY COILS

AVAILABLE FOR USE IN COPPER CYLINDERS.

The EnviroFoam Copper cylinders are also available with a special high performance heat exchanger, on request, which reduces boiler cycling and maximises the time the boiler can operate in condensing mode. These were previously known as our CondenCyl range.

The special coil enables recovery in only 14 minutes which conforms to CHES best practice. The reduction in boiler cycling and faster recovery time combine to reduce the cost of producing hot water.

The high efficiency coil and its ability to heat only the water you require means that a smaller capacity cylinder can be used. For example, a typical 120 litre cylinder to meet Part L1B requirements would reduce to 80 litres using a high recovery coil.

Utilising the EnviroFoam insulation reduces standing losses – particularly beneficial during summer months.

KEY FEATURES

- 2017 ErP compliant
- Standard 1 inch male & female tappings with optional compression fittings available
- High recovery
- Energy saving
- For use with fully pumped systems
- Perfectly matched with condensing boilers
- 100% recyclable

Indirect specifications					
Gledhill code	ErP rating	Cylinder height (mm)	Cylinder diameter (mm)	Capacity (litres)	Rating (kW)
BIND13	C	750	400	80	16
BIND15	C	900	400	96	17
BIND16	C	1050	400	115	17
BIND22	C	900	450	120	17
BIND23	C	1050	450	144	21

SIZES SHOWN ABOVE ARE INDICATIVE. PLEASE QUOTE STANDARD CODES AND ADD EX008 FOR HIGH RECOVERY COIL.

ALL DIMENSIONS EXCLUDE 35MM INSULATION. EXTRA COMPONENTS ARE AVAILABLE WITH THIS PRODUCT. PLEASE SEE PAGE 9 FOR MORE DETAILS.

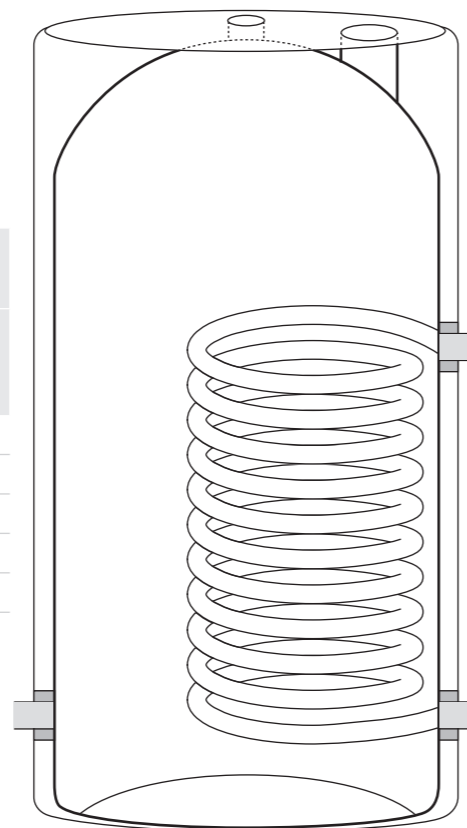

SUPER RECOVERY CYLINDERS

FOR USE WHERE RAPID RECOVERY OF THE CYLINDER CONTENTS IS REQUIRED.

The quick recovery cylinder has a special high performance heat exchanger which reduces boiler cycling and maximises the time the boiler can operate in condensing mode.

Its special coil enables recovery in as little as five minutes, assuming a correctly sized boiler is installed.

The reduction in boiler cycling and faster recovery time combine to reduce the cost of producing hot water.

The super recovery cylinder's high efficiency coil and its ability to heat only the water you require means that a smaller capacity cylinder can be used. This makes it the ideal replacement choice where space is an issue but rapid reheat times are still required.

The cylinders 35mm of high insulation EnviroFoam further reduces standing losses – particularly beneficial during summer months.

KEY FEATURES

- 2017 ErP compliant
- Standard 1 inch male & female tappings with optional compression fittings available
- 10 year warranty
- Recovery from 5 minutes
- Recovers as it is being used
- For use with fully pumped systems
- 100% recyclable

Super recovery specifications				
Gledhill code	BIHR045	BIHR080	BIHR120	
ErP rating	B	C	C	
Cylinder size (mm)	600 x 350	750 x 400	900 x 450	
Cylinder capacity (litres)	46	80	120	
Recovery time in minutes to raise temp. by 40°C for different boiler outputs	9kW	11.9	21.1	31.7
	12kW	8.9	15.8	23.8
	15kW	7.1	12.7	19.0
	24kW	4.6	8.2	11.9
	30kW	3.9	6.9	9.5

ALL DIMENSIONS EXCLUDE 35MM INSULATION. EXTRA COMPONENTS ARE AVAILABLE WITH THIS PRODUCT. PLEASE SEE PAGE 9 FOR MORE DETAILS.

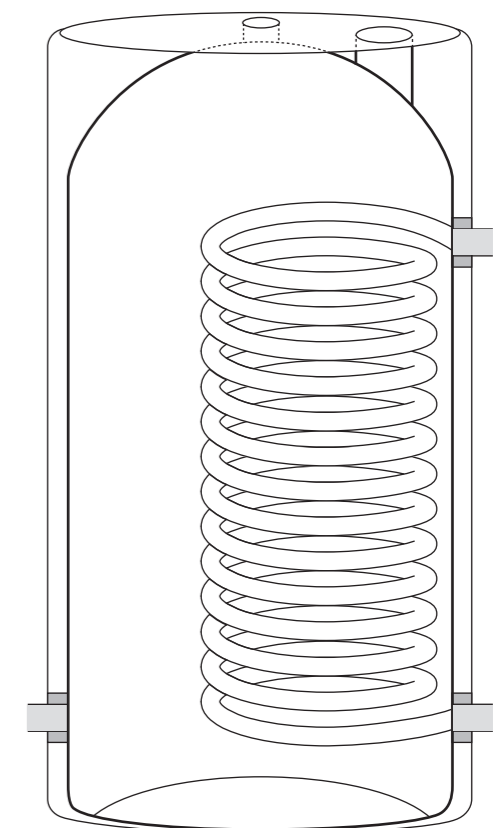

ENVIROFOAM COPPER

COPPER VENTED DIRECT CYLINDER.

Manufactured to BS1566 and 2017 ErP compliant, these cylinders have strong environmental credentials including:

- Industry leading 35mm HCFC free insulation
- Exceptionally low standing heat loss
- Insulation incorporates Polyol which is derived from rapeseed oil - a fully renewable resource
- With a copper internal cylinder, the product is fully recyclable at the end of its working life

As well as being the most attractive open vented copper cylinder available on the market, you will also benefit from:

- Next day lead time availability
- Standard 1 inch male & female tappings with optional compression fittings available
- Easy access to immersion heater boss

KEY FEATURES

- 2017 ErP compliant
- Standard 1 inch male & female tappings with optional compression fittings available
- 10 year warranty
- Low standing heat loss
- 100% recyclable

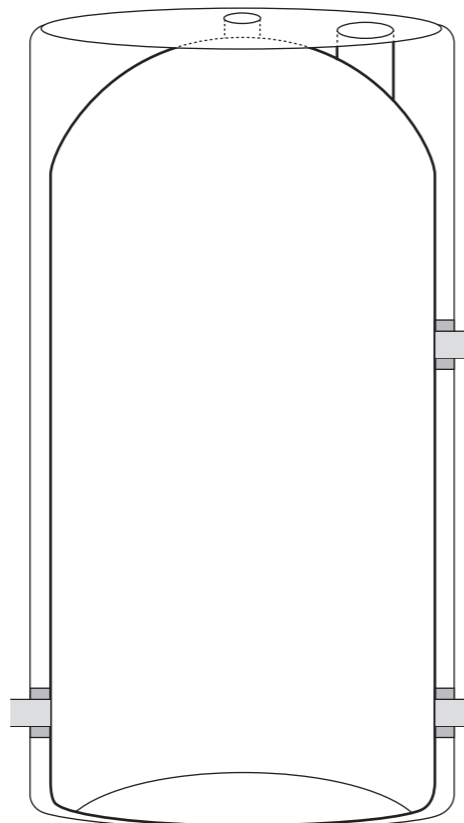

LOOKING FOR BESPOKE?
PLEASE SEE SPECIAL REQUEST FORMS

Gledhill code	ErP rating	BS 1566 ref	Cylinder height (mm)	Cylinder diameter (mm)	Capacity (litres)
BDIR14	C	2	900	400	96
BDIR15	C	3	1050	400	115
BDIR17	B	4	675	450	86
BDIR18	C	5	750	450	98
BDIR19	C	6	825	450	109
BDIR20	C	7	900	450	120
BDIR21	C	8	1050	450	144
BDIR22	C	9	1200	450	166
BDIR23	C	9E	1500	450	218
BDIR25	C	10	1200	500	202

ALL DIMENSIONS EXCLUDE 35MM INSULATION.

ONE OR TWO SIDE IMMERSIONS, AND OTHER ADDITIONAL COMPONENTS, ARE AVAILABLE FOR THESE PRODUCTS, PLEASE SEE PAGE 9 FOR MORE DETAILS.

COMBINATION UNITS

BOTH DIRECT AND INDIRECT CONFIGURATIONS.

The combination cylinder is specifically designed to be installed into properties without a loft space i.e. apartments etc. With the feed tank being incorporated into the combination unit, a separate cold water storage tank is not required, therefore installation is simplified and costs reduced.

With the combination unit, you will also benefit from:

- Standard 1 inch male & female tappings with optional compression fittings available
- High recovery coil available
- Indirect units for use with central heating systems
- BS3198 and 2017 ErP compliant

Direct specifications					
Gledhill code	ErP rating	Cylinder height (mm)	Cylinder diameter (mm)	Capacity hot (litres)	Capacity cold (litres)
BDCOM01	C	900	400	65	15
BDCOM02	C	1050	400	85	20
BDCOM03	B	900	450	85	20
BDCOM04	C	1050	450	115	20
BDCOM05	C	1200	450	115	40
BDCOM06	C	1400	450	144	40
BDCOM07	C	1500	450	166	40
BDCOM08	C	1800	450	210	40
BDCOM18	C	1300	450	130	40

Indirect specifications						
Gledhill code	ErP rating	Cylinder height (mm)	Cylinder diameter (mm)	Capacity hot (litres)	Capacity cold (litres)	Rating (kW)
BICOM01	C	900	400	65	15	9
BICOM02	C	1050	400	85	20	11
BICOM03	B	900	450	85	20	11
BICOM04	C	1050	450	115	20	14
BICOM05	C	1200	450	115	40	14
BICOM06	C	1400	450	144	40	16
BICOM07	C	1500	450	166	40	17
BICOM08	C	1800	450	210	40	22
BICOM16	C	1300	450	130	40	14

ALL DIMENSIONS EXCLUDE 35MM INSULATION.

ONE OR TWO SIDE IMMERSIONS, AND OTHER ADDITIONAL COMPONENTS, ARE AVAILABLE FOR THESE PRODUCTS, PLEASE SEE PAGE 9 FOR MORE DETAILS.

NOT SUITABLE FOR PUMP SHOWERS.

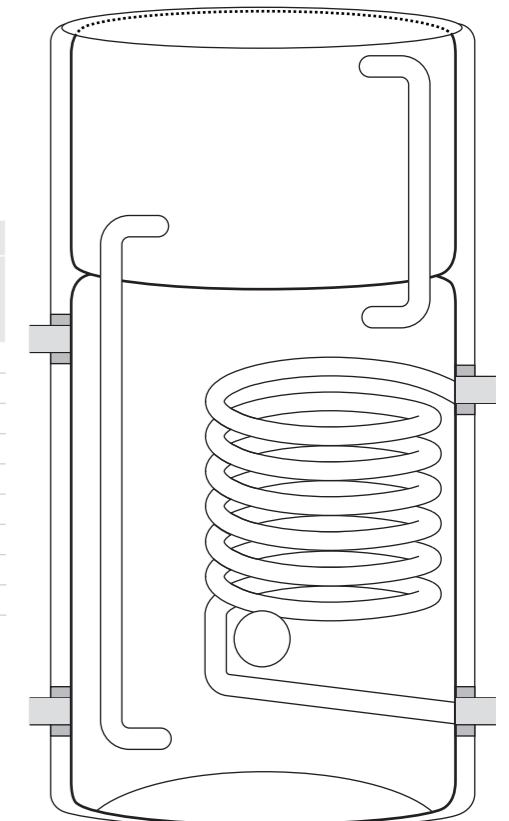
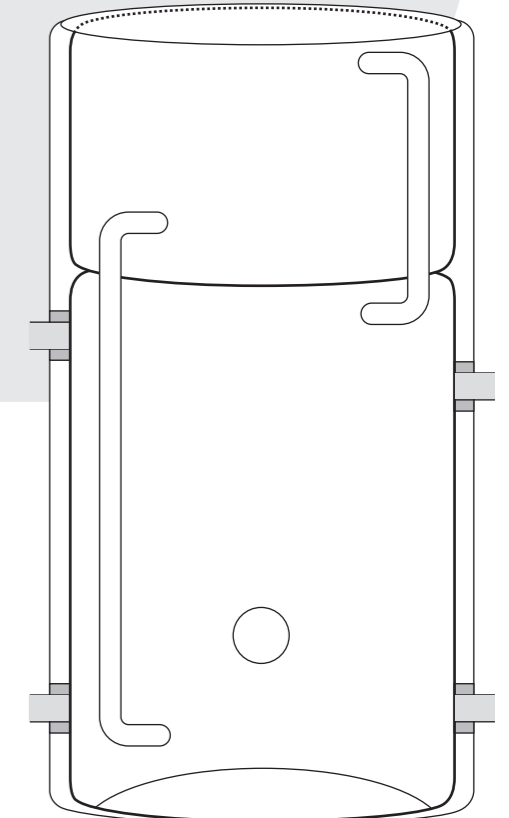

SUNSPEED

DOMESTIC HOT WATER COPPER CYLINDER FOR USE WITH SOLAR ENERGY.

SunSpeed is a domestic hot water cylinder designed for use with solar panels. It is a copper cylinder with two heat exchangers, one for solar input and one for a boiler input.

The dedicated solar volumes range from 34% to 49% with the majority exceeding 40% enabling the best use of the solar panels. These dedicated solar volumes allow maximum suitable solar panels surface area from 2.9m² to 4.4m². The surface area of the solar heat exchanger coil is designed to exceed Building Regulations requirements.

The boiler coil comes into play in the cooler months of the year as the solar input diminishes. A correctly sized cylinder will ensure enough hot water is available to the householder during these months as the dedicated solar volume will not be heated by the boiler. The boiler coil is sized appropriately to the cylinder and gives a recovery time of less than 26 minutes with sizes to meet all regulations.

Indirect specifications					
Gledhill code	ErP rating	Nominal overall capacity (litres)	Cylinder size (mm)	Dedicated solar volume (litres)	Surface area of solar coil (m ²)
BSUN201	C	115	1050 x 400	41	0.29
BSUN202	C	134	1200 x 400	55	0.29
BSUN203	C	146	1300 x 400	61	0.29
BSUN207	C	144	1050 x 450	60	0.29
BSUN208	C	166	1200 x 450	77	0.36
BSUN209	C	188	1300 x 450	84	0.36
BSUN210	C	205	1400 x 450	92	0.43
BSUN211	C	218	1500 x 450	109	0.44

ALL DIMENSIONS EXCLUDE 35MM INSULATION.

The SunSpeed is an open vented cylinder which makes the location of the cylinder more flexible because the cylinder does not require a safety discharge pipe.

The SunSpeed cylinders are insulated using 35mm HCFC free EnviroFoam to comply with Part L of the Building Regulations. This insulation incorporates Polyol which is derived from rapeseed oil - a fully renewable resource. It also provides exceptionally low standing heat loss.

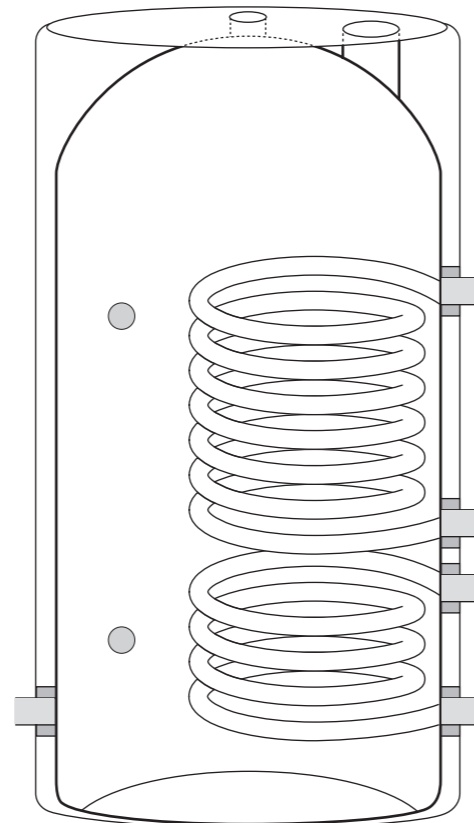

TWIN COIL CYLINDERS

FOR USE WITH TWO HEAT SOURCES - SOLID FUEL AND CONVENTIONAL BOILER.

The twin coil cylinders are designed to be used with two heat sources, including uncontrolled heat sources such as solid fuel (e.g. an Aga stove) alongside a conventional gas or electric boiler.

To boost the efficiency, an optional high recovery coil is available.

The cylinders are available in all three grades, which need to be specified at the time of ordering, and are available in bespoke size and specifications.

All the cylinders are 2017 ErP compliant and come with a 10 year warranty.

Compression fittings are available on these cylinders, but will need to be specified when ordering.

Twin coil specification			
ErP rating	Cylinder height (mm)	Cylinder diameter (mm)	Capacity (litres)
C	900	400	96
C	1050	400	115
C	1200	400	134
C	900	450	117
C	1050	450	144
C	1200	450	166
C	1400	450	205
C	1500	450	218
Combination tanks			
C	1400	400	?
C	1200	450	166
C	1300	450	188
C	1200	500	202
C	1300	500	?

ALL DIMENSIONS EXCLUDE 35MM INSULATION.

SIZES SHOWN ABOVE ARE INDICATIVE. PLEASE QUOTE SIZE AND SPECIFY STACKED OR INTERLOCKED COIL CONFIGURATION AT THE TIME OF ORDER.

TWIN COIL CYLINDERS ARE AVAILABLE IN DIFFERENT COIL CONFIGURATIONS, PLEASE SPECIFY USING THE CODES BELOW.

Gedhill code	Description
EX005	Twin coil - 1 pumped and gravity
EX011	Cradles supplied
EX014	Twin coil - 2 pumped
EX015	Twin coil - 2 gravity

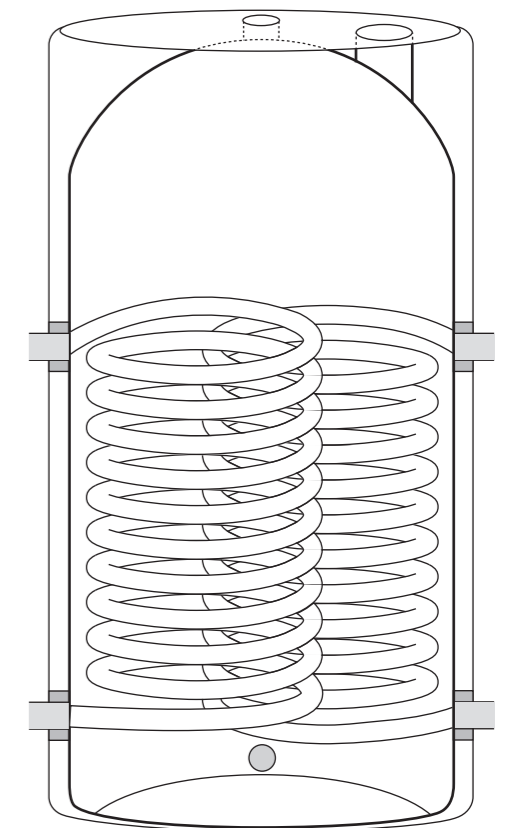

COMMERCIAL CYLINDERS

CYLINDERS AND CALORIFIERS FOR COMMERCIAL AND INDUSTRIAL USES.

Gledhill manufactures a complete range of cylinders and calorifiers for commercial and industrial applications.

Calorifiers are available as standard patterns, horizontal or vertical or high performance types. All are manufactured from high grade copper.

The direct pattern is ideal where the only heat source is electricity, although these can also be made to incorporate a solar coil where a solar input is also available.

The indirect patterns are either 1 or 2 hour recovery as standard, but can be specified for a 30 minute recovery when ordering. These can also be used with solar or solid fuel inputs. Extra tappings or coils are also available to run underfloor heating from.

Capacities can range up to 450 litres and products are individually made to order to accommodate connections and heat exchangers to suit individual applications.

A full range of extras including bolted heads, inspection ports, hand holes and cradles are available if required. Systems with high draw rate potential over extended periods are best served by units with high recovery capability and moderate storage capacity for balancing purposes.

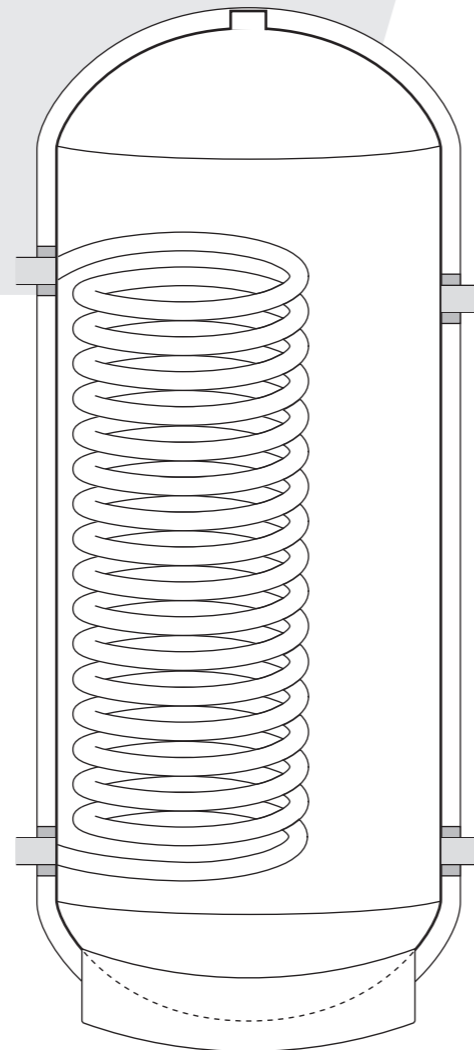

RECTANGULAR TANKS

DIRECT AND INDIRECT RECTANGULAR COMBINATION TANKS.

The combination tanks are supplied in direct and indirect configurations. Both types of unit provide gravity fed hot water and can be installed at high level in a cupboard or in a roof space. The indirect model can also be used on pumped and sealed systems.

The direct model is designed for use with all off-peak tariffs, the thermal properties of the HCFC free insulation ensure low energy costs to the consumer. The direct combination tank ensures a fast, simple installation that will save money, time and materials, and can be supplied fitted with two 3kW immersion heaters and thermostats to make installation even quicker.

Even with future changes to the heating installation the indirect combination tank would not require replacing. For example, should the heating system be changed from open vented to a sealed primary circuit it can be adapted by simply blanking off the primary cold feed and primary vent connections.

Figure 1 shows a hot water store designed for use with electric.

Figure 2 shows a hot water store designed to be used with a sealed system or it can be used with a separate F&E tank for a fully pumped system.

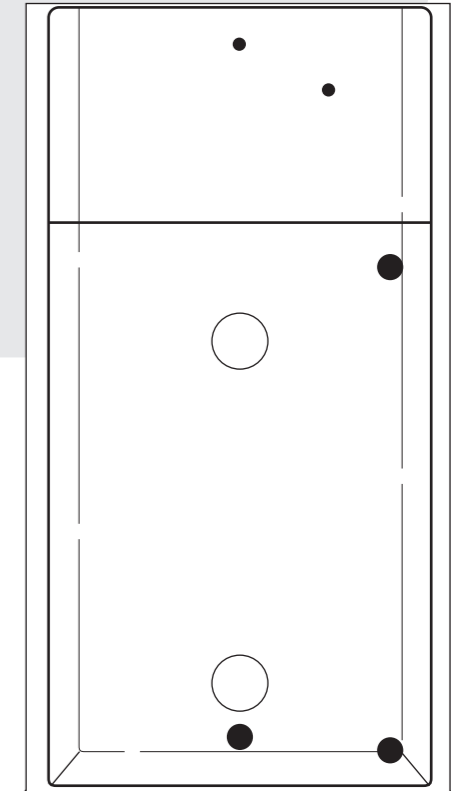

Figure 1.

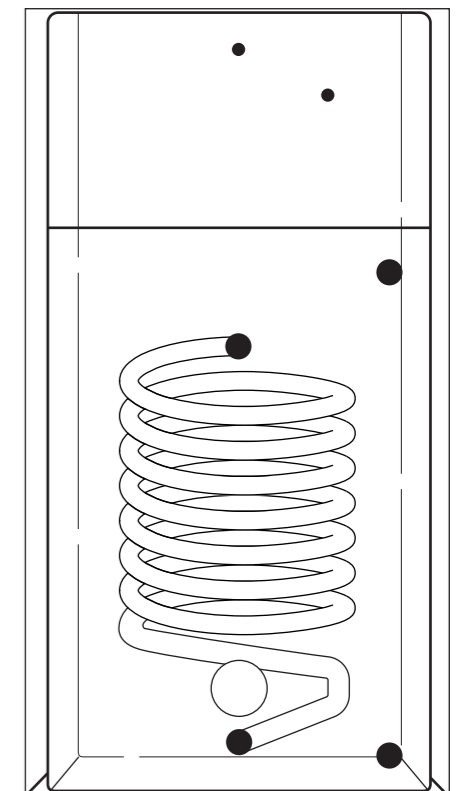

Figure 2.



MADE TO ORDER
CONTACT OUR DEDICATED TEAM AT
OUR BLACKPOOL HEADQUARTERS
WITH YOUR REQUIREMENTS



MADE TO ORDER
CONTACT OUR DEDICATED TEAM AT
OUR BLACKPOOL HEADQUARTERS
WITH YOUR REQUIREMENTS

**SPLIT HEADER
TANK AVAILABLE**
PLEASE SPECIFY AT TIME OF ORDER
SEPARATE COLD TANKS ARE ALSO
AVAILABLE ON REQUEST

TORRENT STAINLESS

THERMAL STORES PROVIDING BOTH HEATING AND MAINS PRESSURE HOT WATER.

A thermal store provides the perfect solution to a home's heating and hot water requirements. Torrent Stainless offers more options than any other store or cylinder, and is designed to reduce heating costs by offering complete flexibility for householders to use multiple energy sources.

The Torrent Stainless enables the hot water within the store to circulate around the heating system to provide heat to the property, with the domestic hot water being mains cold water instantaneously heated through a plate heat exchanger.

Thermal stores provide many additional benefits including:

- Mains pressure hot water
- No annual maintenance or safety check requirement
- No discharge pipework
- No risk of legionella
- No G3 qualification requirement for installation

The Torrent Stainless is manufactured from high specification duplex stainless steel by our trained engineers at our Blackpool headquarters.

Homeowners should select the thermal store which best suits their requirements, allowing them to maximise the available heat sources, whether they are traditional boilers, electric immersions, or increasingly popular alternative energy fuel sources.

The cylinder is open vented, enabling uncontrolled heat sources such as woodburning stoves to be used.



IMMERSION HEATER



GAS OR OIL BOILERS



SOLID FUEL



SOLAR THERMAL

LEGIONELLA & SCALD PROTECTION

The domestic hot water is generated by mains cold water being instantaneously heated as it passes through the heat exchanger, which is then delivered to the taps. This method of generating the hot water completely removes the risk of legionella. Gledhill's patented intelligent controls, in conjunction with the sensors, regulate the hot water temperature. Blending valves at the shower and bath outlet prevent the risk of scalding.

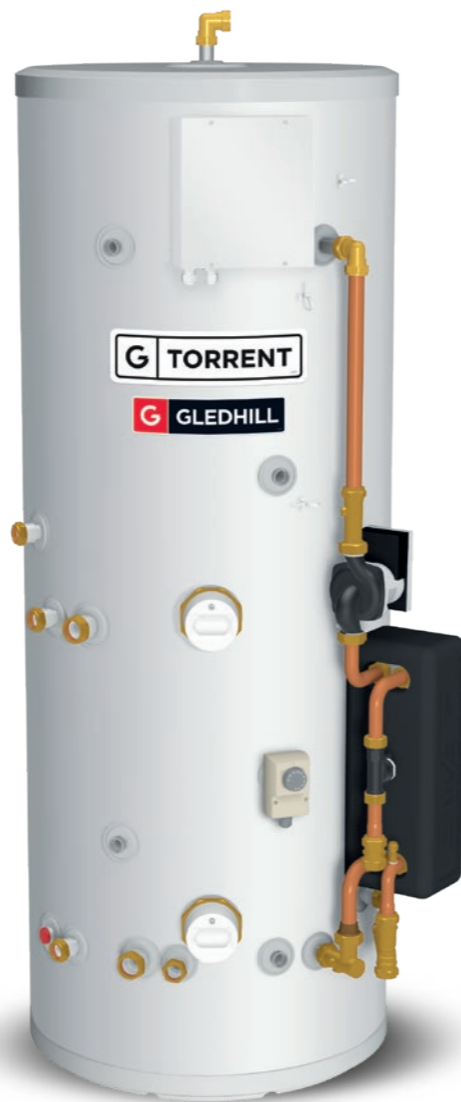

TORRENT STAINLESS OV

Description		TST150OV	TST180OV	TST210OV	TST250OV	TST350OV
ErP rating		B	B	B	C	C
Heat loss	watts	47	55	62	74	79
Capacity	litres	148	178	208	248	345
Unit height	mm	1118	1306	1494	1744	1765
Unit diameter	mm	550	550	550	550	630
Max. hot water flow rate	litres/minute	26.5	26.5	26.5	26.5	26.5
	bath	1	1	2	2	3
Maximum dwelling type	shower room	-	1	1	2	2
	bed	1-2	2-3	2-3	3-4	4-5

TORRENT STAINLESS OV SOL

Description		TST150OVSOL	TST180OVSOL	TST210OVSOL	TST250OVSOL	TST350OVSOL
ErP rating		B	B	B	C	C
Heat loss	watts	47	55	62	74	79
Capacity	litres	148	178	208	248	345
Unit height	mm	1118	1306	1494	1744	1765
Unit diameter	mm	550	550	550	550	630
Dedicated solar volume	litres	64	74	84	97	130
Max. solar collector area ¹	m ²	2.22	2.54	2.91	3.88	4.64
Solar heat exch. surface area	m ²	0.78	0.78	1.27	1.27	1.27
Max. hot water flow rate	litres/minute	26.5	26.5	26.5	26.5	26.5
	bath	1	1	1	2	2
Maximum dwelling type	shower room	-	-	1	1	2
	bed	1-2	2-3	2-3	3-4	4-5

TORRENT STAINLESS SP SOL

Description		TST150SPSOL	TST180SPSOL	TST210SPSOL	TST250SPSOL	TST350SPSOL
ErP rating		B	B	B	C	C
Heat loss	watts	47	55	62	74	79
Capacity	litres	148	178	208	248	345
Unit height	mm	1118	1306	1494	1744	1765
Unit diameter	mm	550	550	550	550	630
Dedicated solar volume	litres	64	74	84	97	130
Max. solar collector area ¹	m ²	2.22	2.54	2.91	3.88	4.64
Solar heat exch. surface area	m ²	0.78	0.78	1.27	1.27	1.27
Max. hot water flow rate	litres/minute	26.5	26.5	26.5	26.5	26.5
	bath	1	1	1	2	2
Maximum dwelling type	shower room	-	-	1	1	2
	bed	1-2	2-3	2-3	3-4	4-5

NOTES:

¹ To comply with the Building Regulations ADL1 Domestic Heating Compliance Guide.

Please refer to the relevant installation manual for further information.

G GLEDHILL SPECIAL ORDERS

INSTALLER NAME: _____

COMPANY: _____

PHONE NO: _____

MERCHANT: _____

PHONE NO: _____

(H) height (ø) diameter

SIZE: (H) _____ (ø) _____

TAPPING POSITIONS

Please show size and position of bosses and floor to centre measurements if critical.

Don't forget shower take-offs, drain connections and secondary returns can be factory fitted!

15, 22, 28 compression with nut & olive or 1/2" up to 2" screwed connections. Please refer to page 9 for alternative connection codes.

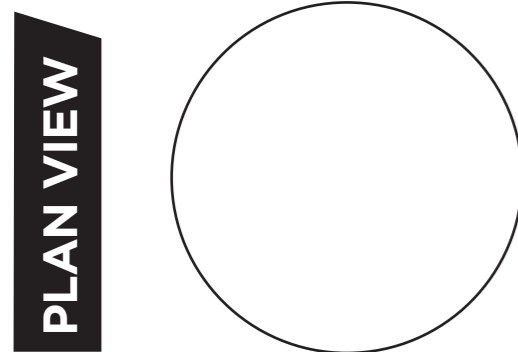
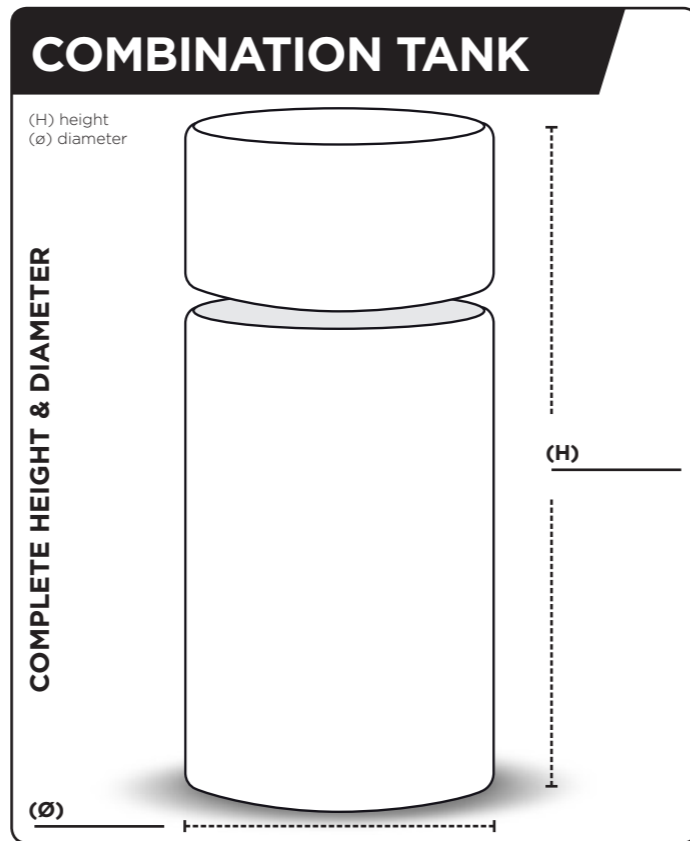
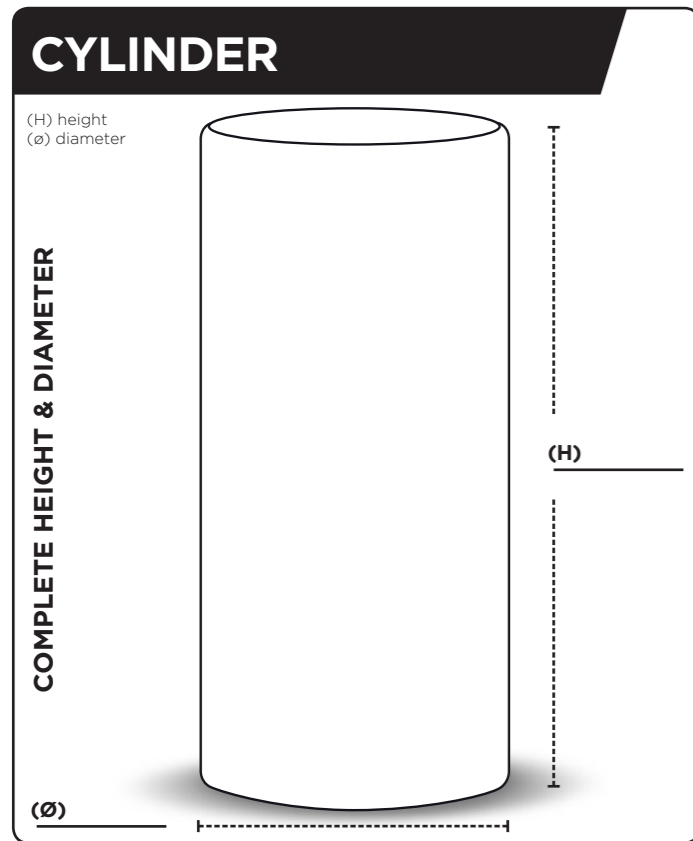

ADDITIONAL DETAILS

WORKING HEAD	
	10m
	15m
	25m
	31m

TYPE	
	Direct
	Indirect
	Automatic
	Solar Sunspeed

INSULATION	
	Foam
	64mm Lamicil

G GLEDHILL SPECIAL ORDERS

INSTALLER NAME: _____

COMPANY: _____

PHONE NO: _____

MERCHANT: _____

PHONE NO: _____

(H) height (W) width (D) depth

SIZE: (H) _____ (W) _____ (D) _____

TAPPING POSITIONS

Please show size and position of bosses and floor to centre measurements if critical.

Don't forget shower take-offs, drain connections and secondary returns can be factory fitted!

15, 22, 28 compression with nut & olive or 1/2" up to 2" screwed connections. Please refer to page 9 for alternative connection codes.

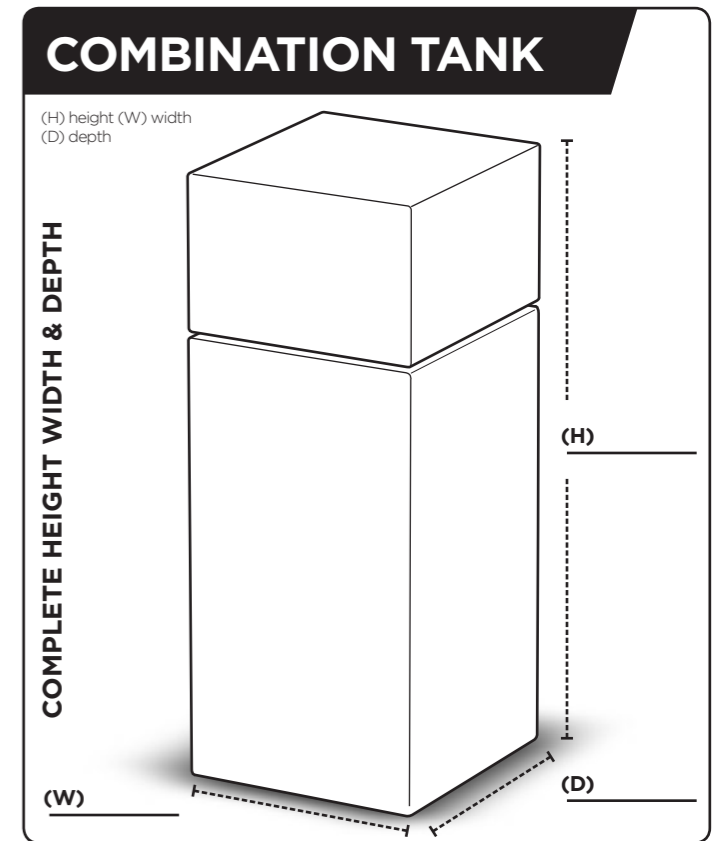
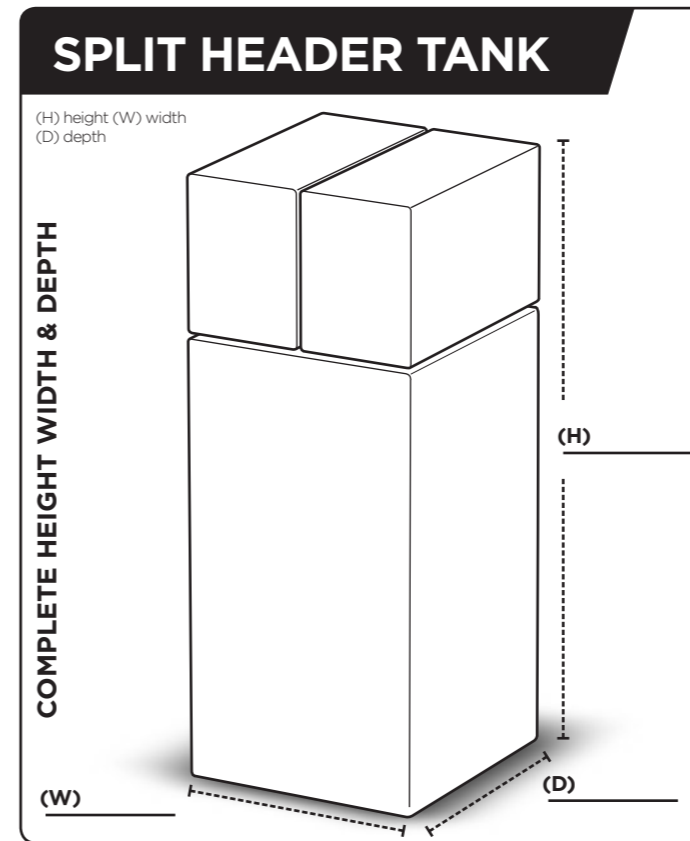

ADDITIONAL DETAILS

TYPE	
	Direct
	Indirect

SPARES

Gledhill cylinders are manufactured to the highest quality standards. In the unlikely event that you require a spare part, you can contact Gledhill Spare Parts, on:

01253 474412

or visit www.gledhill-spares.net

HERE TO HELP

If you're looking for technical assistance while you're on the job, give our technical team a call. With many years' experience, they're an invaluable resource to have at the end of the phone.

FOR TECHNICAL
ADVICE PLEASE CALL
01253 474584



Gledhill Building Products Limited
Sycamore Estate,
Squires Gate,
Blackpool FY4 3RL

T: 01253 474550
E: enquiries@gledhill.net

WWW.GLEDHILL.NET



FM 02057



Due to a programme of continuous improvement Gledhill Building Products reserves the right to modify products without prior notice. It is advisable to check the product technical detail by using the latest design and installation manuals available from our technical support team or on our website. It is an offence to copy or adapt this document without consent of the owner.